



**MISSION
ENGINEERING**

**GEMINI
1-P**



**USER
GUIDE**

INTRODUCTION

Congratulations on your purchase of the Mission Gemini 1-P passive guitar speaker. This product is designed to be intuitive to setup and operate, and to provide many years of trouble free service.

However, we recommend that you take a few moments to read through this User Guide in order to get the best possible experience with your new speaker.

BACKGROUND

The Gemini 1-P is a professional quality, passive speaker cabinet specifically designed for use with software based music systems such as guitar modeling amplifiers, cabinet simulators, and digital audio workstations.

A traditional guitar speaker cabinet is typically designed to work best in conjunction with a guitar amplifier. The speaker works within a limited frequency range, and the cabinet and speaker themselves contribute to the overall tone. While this works perfectly with an analog guitar rig, it is not always an ideal solution for digital systems.

Software based modelers usually implement guitar cabinet simulators designed to emulate specific speaker cabinets in software. If the signal subsequently passes through a physical speaker cabinet with its own tonal characteristics, it colors the eventual tone, making the modeling less accurate. Additionally, guitar speaker cabinets do not often work well with signals other than guitar such as keyboards, vocals, and playing back recorded music. The Mission Gemini amplifiers and cabinets resolve these problems as they are specifically designed to work with software based music systems.

FEATURES

The Gemini 1-P is a passive speaker cabinet designed to work with an external power amplifier, and

faithfully reproduce a modeled signal chain. The cabinet is fitted with a 12" low frequency driver, and 1" high frequency compression driver in a co-axial configuration: The high frequency driver is mounted in the center of the low frequency driver.

The Coaxial driver configuration has been used for over sixty years in professional audio monitoring and high-end audiophile applications. The benefits include a wider field of dispersion that's more uniform across the frequency spectrum. This means listeners do not have to be positioned directly in front of the speaker to get the best experience. The full frequency range also appears to the listener to originate from a single source, without any apparent physical separation between low and high frequencies. Since the high frequency driver is located at the center of the driver, the cabinet can be used with a microphone, with the high frequencies accentuated as the microphone is positioned towards the center of the speaker, replicating the on/off axis positioning of a traditional guitar cab. These features make the Gemini 1-P ideal for live, recording, and monitoring use.

RECOMMENDED AMPLIFIERS

The Gemini 1-P works best with solid state power amplifiers rated between 50w and 250w RMS into 8 ohms, or tube amplifiers rated between 10w and 75w RMS into 8 ohms. Amplifiers rated at higher than the recommended output power can certainly be used, but care should be taken not to consistently input greater than the recommended levels as damage to the drivers can occur.

Gemini passive cabinets feature a unique protection circuit that reduces the likelihood of damage to the high frequency driver if input power should exceed 250w. An analog compressor tracks the source material and provides almost 5dB of attenuation at peak power. This feature protects the driver against

damage while maintaining the musical quality of the signal.

CONNECTIONS

There is one input and one output on the rear panel of the Gemini 1-P. Connect the output of one channel of your power amplifier to the input of the Gemini. If you have one or more amplifiers with multiple channels you can connect Gemini 1-P cabinets to each channel to increase the overall sound pressure level and/or to support stereo or other multi-channel audio signals.

Gemini cabinets use a combination connector that supports either Speakon or ¼" jack connections. Speakon cables are recommended, if available, as they provide a safer and more reliable connection in most cases. If these are not available a standard ¼" TS guitar cable can be used.

The output allows two Gemini cabinets to be linked together in parallel to a single power amp channel. Connect the output from the amplifier to the input on the Gemini cabinet #1. Connect the output from cabinet #1 to the input on cabinet #2. Again, either Speakon or ¼" cables can be used.

Please note that in parallel configuration, the speakers will present a 4 ohm impedance rather than the 8 ohm impedance of a single cabinet. It is important to make sure that your power amplifier is designed to operate with a 4 ohm load. Using parallel mode with amplifiers not intended for use with 4 ohm speakers can result in permanent damage to the amplifier and speaker drivers. Double check this with your amplifier manufacturer if you are not sure, before connecting the Gemini 1-P in parallel mode.

WARNING It is not recommended to exceed two cabinets connected in parallel mode. Connecting three cabinets will present a 2 ohm impedance. Most amplifiers are not intended to be used with 2 ohm speaker drivers, and damage to the amplifier may result.

MULTI SPEAKER CONFIGURATION

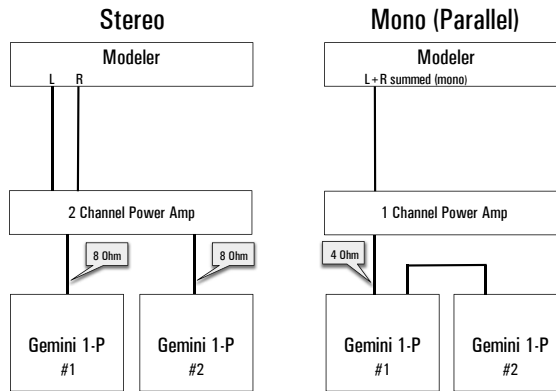

SPECIFICATIONS

Power Handling	250W RMS
Frequency Response	66Hz - 20KHz + _ 2dB
Crossover	Passive at 2.5KHz
Impedance	8 Ohm
Input	Combo Speakon ¼" jack
Output	Combo Speakon ¼" jack

DIMENSIONS

Width	24" (610mm)
Height	20" (508mm)
Depth	12" (305mm)
Weight	42lbs (19kg)

MISSION ENGINEERING INC.

www.missionengineering.com
info@mission-engineering.com

©Mission Engineering Inc. 2014. All rights reserved. GEMINI 1-P is a Trademark of Mission Engineering Inc. Trademarks, registered trademarks, product names, logos and other materials are the property of their respective owners.

SAFETY INSTRUCTIONS

- Read, Keep & Follow these instructions
- Heed all warnings
- Clean only with dry cloth
- Do not use this apparatus near water
- Do not expose the apparatus to dripping or splashing and ensure that no objects filled with liquids, shall be placed on the apparatus
- **WARNING:** To reduce the risk of fire or electric shock do not expose this apparatus to rain or moisture
- Unplug this apparatus during lightning storms or when unused for long periods of time
- Do not block any ventilation openings. Install in accordance with the manufacturer's instructions
- Only use attachments/accessories specified by the manufacturer
- Prolonged listening at high volume levels may cause irreparable hearing loss and/or damage. Always be sure to practice "safe listening."
- Refer all servicing to qualified service personnel. Service is required when the apparatus has been damaged in any way, such as:
 - power-supply cord or plug is damaged
 - liquid has been spilled or objects have fallen into the apparatus
 - the unit has been exposed to rain or moisture.
 - the unit is dropped or the enclosure is damaged
 - the unit does not operate normally or changes in performance in a significant way
- Dismantling, rewiring, removing components or otherwise altering the function of the unit may cause unexpected behavior and will invalidate the warranty.